

New!

The pneumatic Pinch Valve type VMP-Compact

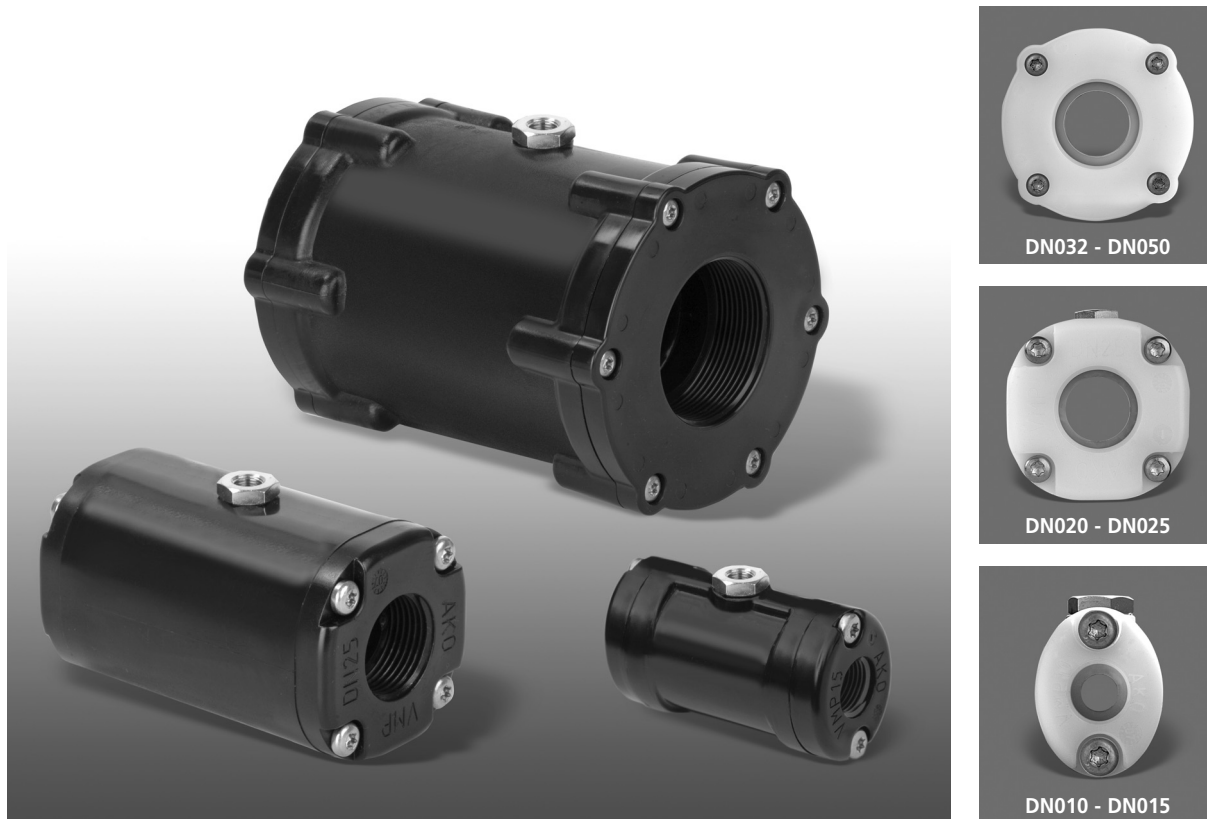

▲ Reliable and cost-effective!

The compact valve solution for the automatic shut off.
For example dust, granule, powder, suspension, sewage, air venting etc.

Advantages:

- Extremely compact – face to face length reduced up to 30%
- Weight reduced by 25%
- Suitable for food applications
- ATEX conformity
- Excellent weather resistance
- Complete free passage
- No plugging
- 100% tight shut off
- Easy maintenance and re-sleeving

The pneumatic Pinch Valve Type VMP-Compact

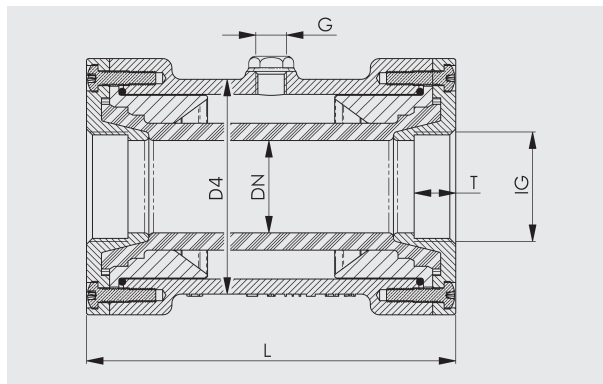
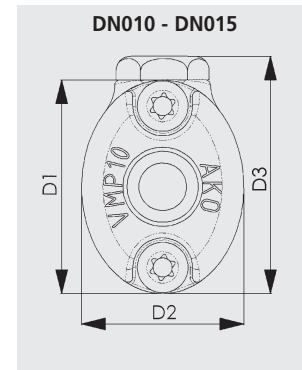
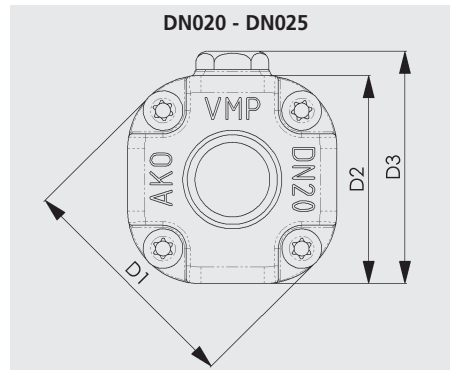
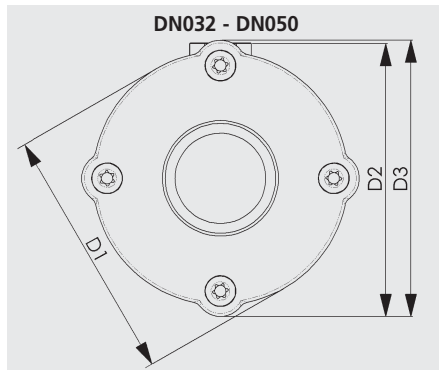

Industrial areas:

- Pneumatic conveying systems
- Pigments and granules
- Ceramics/glass/plastic industry
- Pharmaceutical/food industry
- Extraction systems
- Dosing systems
- Filling and weighing systems
- Air venting systems

| DN (mm) | IG (inch) | T (mm) | L (mm) | D1 (mm) | D2 (mm) | D3 (mm) | D4 (mm) | G (inch) | PS max. (bar) | screws | volume (ml)* (approx.) | weight (kg) |
|---------|----------------------------------|--------|--------|---------|---------|---------|---------|----------|---------------|--------|------------------------|-------------|
| 10 | G ³ / ₈ " | 12 | 80 | 45 | 34 | 50 | 45 | 1/8" | 6,0 | 4 | 15 | 0,15 |
| 15 | G ¹ / ₂ " | 14 | 95 | 55 | 46 | 60 | 55 | 1/8" | 6,0 | 4 | 25 | 0,25 |
| 20 | G ³ / ₄ " | 17 | 103 | 63 | 56 | 62,5 | 56 | 1/8" | 6,0 | 8 | 40 | 0,35 |
| 25 | G1" | 17 | 120 | 75 | 70 | 75 | 70 | 1/8" | 6,0 | 8 | 80 | 0,50 |
| 32 | G1 ¹ / ₄ " | 18 | 135 | 90 | 98 | 97 | 77 | 1/4" | 4,5 | 8 | 150 | 0,65 |
| 40 | G1 ¹ / ₂ " | 18 | 160 | 103 | 111 | 110,5 | 93 | 1/4" | 4,5 | 8 | 300 | 1,00 |
| 50 | G2" | 24 | 170 | 120 | 130 | 129 | 113 | 1/4" | 4,5 | 12 | 450 | 1,50 |

* Volume = Control volume with closed sleeve

Standard adaption:

Internal pipe thread (DIN 2999) or NPT, others on request

Materials:

Body/socket ends:

- POM natural white** FDA approved
- POM black** excellent weather resistance
- POM conductive** ATEX conformity

Sleeves:

Natural rubber anti-abrasive, natural rubber food quality, EPDM, Nitrile, Hypalon, Butyl, Neoprene, others on request

Technical changes kept in reserve

AKO UK Ltd

13 Alvis Way, Royal Oak Trading Estate, Daventry, Northants NN11 8PG.
 Tel: 013 27 31 27 47 • Fax: 013 27 31 25 65 • e-mail: sales@ako-valves.com • Web: www.ako-valves.com