

# Type C

## HOPPER SHAPE KNIFE GATE VALVE

The **C** model knife gate is a uni-directional wafer valve designed for industrial bulk handling service applications (powdered and granular products). The special design of the body allows for easy passage of the fluid and makes it ideal for use as silo outlet valve. Widely used in industries such as:

- Power plants
- Chemical plants
- etc.
- Food and Beverage
- Mining

The valve is normally installed in the reverse position (seat upstream) in order to avoid problems like build-up in valve body, seat wear, difficult closing,...

Sizes: DN 50 to DN 600 (larger diameters on request)

	OFF SEATING	ON SEATING
Working pressure:	(Standard)	
DN 50 to DN 250	3 kg/cm <sup>2</sup>	10 kg/cm <sup>2</sup>
DN 300 to DN 400	2 kg/cm <sup>2</sup>	6 kg/cm <sup>2</sup>
DN 450	1,5 kg/cm <sup>2</sup>	5 kg/cm <sup>2</sup>
DN 500 to DN 600	1 kg/cm <sup>2</sup>	4 kg/cm <sup>2</sup>

Standard flange connection:

DIN PN 10 and ANSI B16.5 (class 150)

Note: other flange connections are available on request.

Directives: DIR 98/37/CE (MACHINES)  
DIR 97/23/CE (PED)  
DIR 94/9/CE (ATEX)

All valves are tested prior to shipping in accordance with the standard developed by the Quality Control Department.

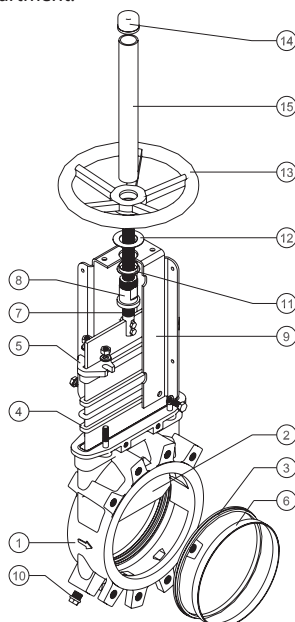

### STANDARD PARTS LIST

Part:	Cast Iron:	Stainless Steel:
1- Body	GJL 250 (GG25)	CF8M
2- Gate	AISI 304	AISI 316
3- Seat	Metal or EPDM	
4- Packing	Tallowed cotton	PTFE Impreg. Synth. Fibre
	(Both versions with EPDM o-ring)	
5- Gland Follower	Aluminum (DN 50 to DN 300) Ductile Iron (DN 350 to DN 600)	CF8M
6- Seat retainer ring	AISI 304	AISI 316
7- Stem	AISI 303	
8- Stem nut	Brass	
9- Yoke	Carbon Steel - Epoxy coated	
10- Cleaning	Carbon Steel	
11- Collar	Nylon	
12- Friction washer	Brass	
13- Handwheel	∅ ≤ 310: Ductile Iron / ∅ ≥ 410: GJL 250 (GG25)	
14- Cap	Plastic	
15- Stem Protector	Epoxy-coated Carbon Steel	

# Type C

## DESIGN FEATURES

### **BODY:**

Wafer style cast **monoblock** design with reinforced ribs in larger diameters for extra body strength.

Internal cast gate wedges and guides allow for tighter shut-off.

Special cast gate supports prevent seat from deflecting off the gate when valve is installed in the reverse position of the flow direction.

Wide face to face and internal design with flushing corners avoid any build up of solids that would prevent valve from closing.

Full port design for greater flow capacity and minimal pressure drop.

Standard flush ports allow cleaning of solids trapped within the body cavities that can obstruct the flow or sealing in the closed position.

Purge ports can be injected with air, steam, liquids, etc. depending on the media.

### **GATE:**

Stainless steel gate as standard.

Gate is polished on both sides to avoid jamming and seat damage.

Bottom of the gate edge is machined to a bevel to cut through solids for a tighter seal in the closed position. On request: thickness and/or material of the gate can be changed for higher pressure requirement.

### **SEAT:** (resilient)

Unique design that mechanically locks the seat in the internal of the valve body with a stainless steel retainer ring.

Standard EPDM also available in different materials such as Viton, PTFE, etc.

### **PACKING:**

Long-life packing with several layers of braided fibre plus an EPDM o-ring, with an easy access packing gland ensuring a tight seal.

Long-life braided packing is available in a wide range of materials.

### **STEM:**

The standard stainless steel stem offers a long corrosion resistant life.

For rising stem handwheel actuators only, a stem protector is provided for additional protection against dust while the valve is in the open position.

### **ACTUATORS:**

All actuators are interchangeable, and supplied with an standard mounting kit to allow for interchangeability on site.

### **YOKE or ACTUATOR SUPPORT:**

Made of EPOXY coated steel (stainless steel available on request).

Compact design makes it extremely robust even under the most severe conditions.

Reinforced design is standard starting from DN 250.

### **EPOXY COATING:**

The epoxy coating on all AKO cast iron and carbon steel valve bodies and components is electrostatically applied making the valves to be corrosion resistant with a high quality finished surface.

The AKO standard colour is RAL-5015 blue.

### **GATE SAFETY PROTECTION:**

AKO automated valves are provided with gate guards in accordance with **EU** Safety Standards.

The design feature prevents any objects from being caught accidentally while the gate is moving.



## OTHER OPTIONS

### **Bonnet (Fig.1):**

Assures tight sealing to atmosphere for use with hazardous gas or fluids.  
Reduces packing maintenance.

### **Other materials of construction:**

Special alloys such as AISI 317, 254SMO, Hastelloys, Titanium,...

### **Fabricated valves:**

AKO is equipped for in house fabrication of special valves.  
Depending on the design, diameter, pressures, material of construction,...

## SURFACE TREATMENTS

Valve components can be protected or coated for a longer life expectancy, depending on the application and the service conditions.

We can offer treatments and coatings for the valve components to improve the properties against **abrasion** (Stellite, Polyurethane...), **corrosion** (Halar, Rilsan, Galvanised...) and **adherence** (Polishing, PTFE...).

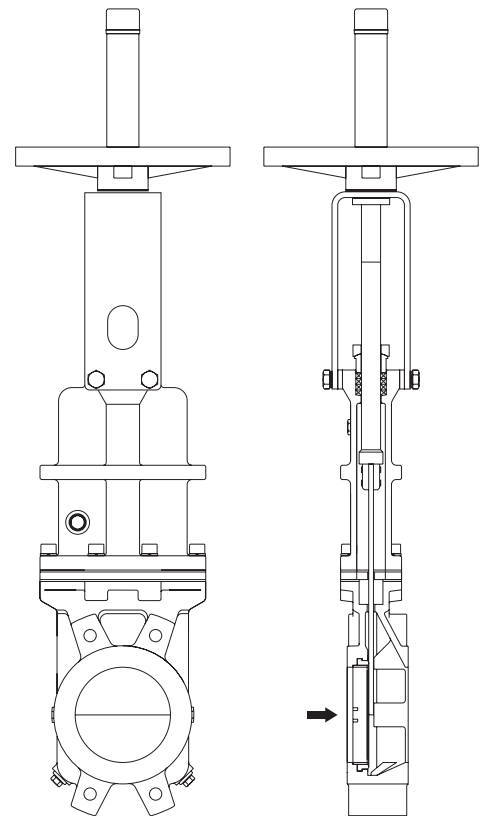

**Fig.1**

We recommend consultation with our technical department.

## ACTUATOR TYPES

### Manual:

Handwheel (rising & non-rising stem)  
Chainwheel  
Lever  
Bevel Gear  
Others (square nut...)

### Automatic:

Electric  
Double Acting Pneumatic  
Single Acting Pneumatic  
Hydraulic

All actuators supplied by AKO are interchangeable.

### FAIL SAFE SYSTEMS

Used on pneumatic actuated valves,

#### SINGLE ACTING / SPRING RETURN

Available from DN 50 to DN 200

Options:

- Fail open
- Fail closed

#### SINGLE ACTING / VOLUME TANK

Available for all sizes (DN>200)

Options:

- Pneumatic Failsafe
- Pneumatic or Electric Failsafe

### ACCESSORIES

- Mechanical stops
- Locking device
- Manual override
- Solenoid valves
- Positioners
- Limit switches
- Proximity switches
- Floor stands
- Stem extensions

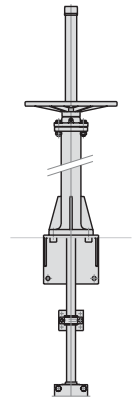

Wide range of valve extensions available.

*For further information about fail safe systems and valve extensions, please see A chapter.*

*We recommend consultation with our technical department.*

## TEMPERATURE CHART

SEAT / SEALS			PACKING		
Material	Max.Temp.(°C)	Applications	Material	Max. Temp. (°C)	pH
Metal/Metal	>250	High temp. Low tightness.	Cotton (A, H)	50	6 - 8
EPDM (4)	120	Acids and non mineral oils.	PTFE impregn. synth. fibre (E)	240	2 - 13
Nitrile (7)	120	Resistance to petroleum products.	Braided PTFE (G)	260	0 - 14
Viton (5)	200	General chemical service. High temperature.	Graphited (B)	450	0 - 14
Silicone (6)	250	Food service. / High temperature.	Ceramic fibre (J)	1200	—
PTFE (9)	250	Corrosion resistance.	NOTE: all types include an elastomere O-ring (same material as seal), excluding G, B and J.		

More details and other materials under request.

## SEAT TYPES

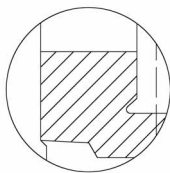

### METAL / METAL

For applications with:

- High temperature
- High density media application
- When full tightness is not required

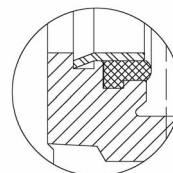

### RESILIENT, TYPE "A"

- Standard resilient seat
- Temperature limitations according to seat material selected. Consult the above chart or our technical department for more information.
- Replaceable seat retainer ring.

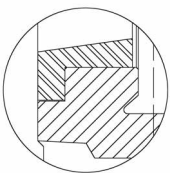

### TYPE "B" SEAT (metal/metal)

For applications with:

- High temperature
- High density media application
- When full tightness is not required
- Replaceable design without dismantling the valve

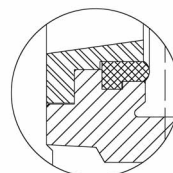

### TYPE "B" SEAT (resilient)

- Temperature limitations according to seat material selected. Consult the above chart or our technical department for more information.
- Replaceable and reinforced seat ring available in different materials such as: stainless steel, CA15, Ni Hard,...

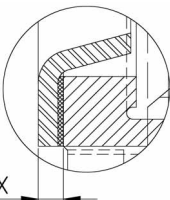

### DEFLECTION CONE "C"

- Deflects the media away from any internal exposed parts of the valve such as gate guides, seat, etc.
- Different types of material available such as AISI 316 stainless, CA15, Ni-Hard, etc.

Face to face dimensions increase:

DN 50 to DN 250	X = 9mm
DN 300 to DN 600	X = 12mm

Larger diameters on request

# Type C

## HANDWHEEL (rising stem)

- Standard handwheel actuator.
- Consists on:
  - Handwheel: Epoxy coated Cast Iron
  - Stem
  - Stem nut
  - Stem protector
- Available from DN 50 to DN 600
- Options (on request):
  - Locking Device
  - Extensions and floor stand

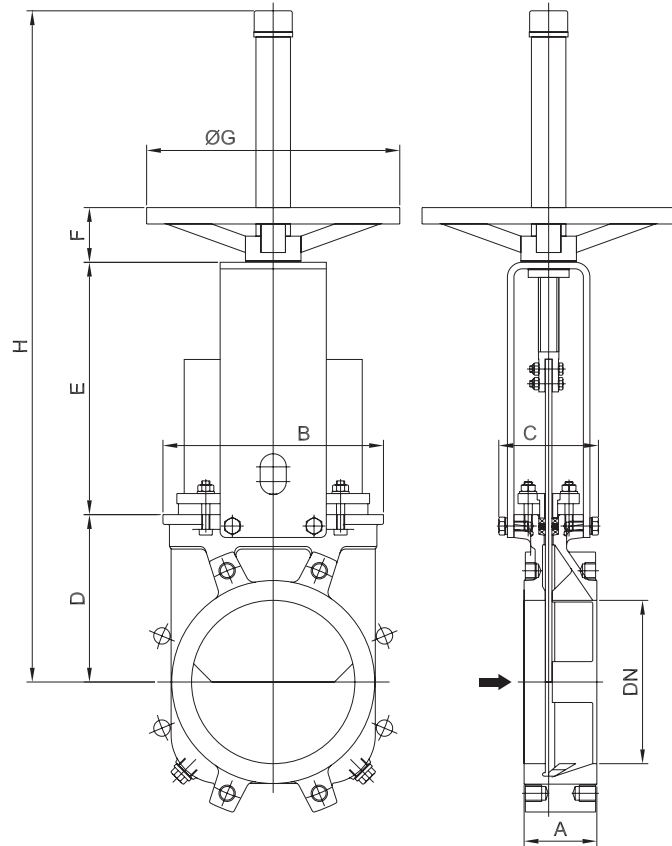

DN	A	B	C	D	E	F	ØG	H	Weight (kg.)
50	46	124	100	105	129	47	225	420	7
65	46	139	100	115	146	47	225	450	8
80	64	154	100	124	162	47	225	475	9
100	64	174	100	140	187	47	225	520	11
125	70	192	100	150	211	47	225	600	15
150	76	217	100	170	237	47	225	647	18
200	89	270	122	205	309	67	310	822	30
250	114	326	270	240	364	67	310	1012	44
300	114	380	270	280	414	67	310	1102	58
350	127	438	270	320	486	66	410	1305	96
400	140	493	270	350	536	66	410	1385	124
450	152	546	270	420	588	66	550	1582	168
500	152	620	270	450	648	66	550	1672	192
600	178	714	270	530	748	66	550	1962	245

# Type C

## HANDWHEEL (non-rising stem)

- Recommended for installation where space is limited.
- Consists on:
  - Handwheel: Epoxy coated Cast Iron
  - Stem
  - Yoke bushing
  - Stem nut fixed to the gate
- Available from DN 50 to DN 600
- Options:
  - Locking Device
  - Extensions
  - Square Nut Drive

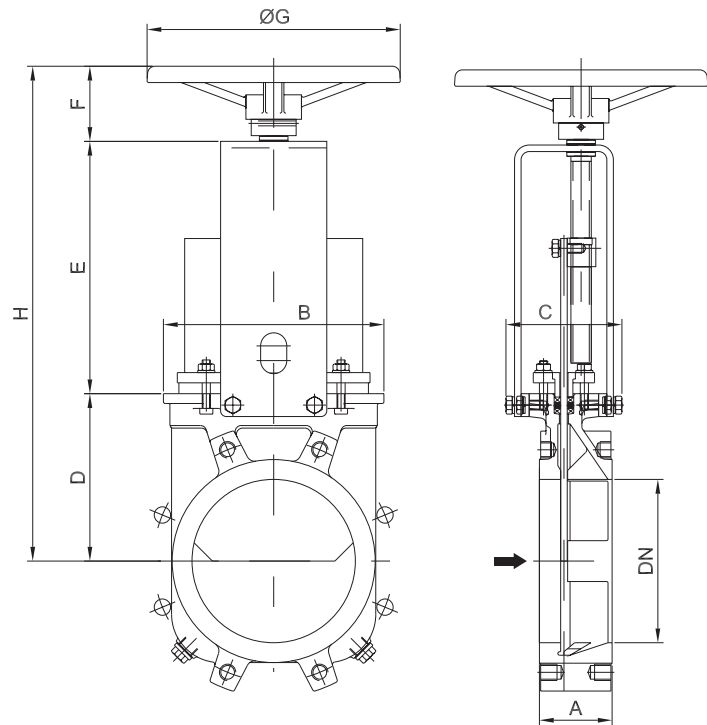

DN	A	B	C	D	E	F	ØG	H
50	46	124	125	105	132	78	225	315
65	46	139	125	115	149	78	225	342
80	64	154	125	124	165	78	225	367
100	64	174	125	140	190	78	225	408
125	70	192	125	150	214	78	225	442
150	76	217	125	170	240	78	225	488
200	89	270	142	205	305	92	310	602
250	114	326	270	240	360	92	310	692
300	114	380	270	280	410	92	310	782
350	127	438	270	320	487	110	410	917
400	140	493	270	350	537	110	410	997
450	152	546	270	420	589	111	550	1120
500	152	620	270	450	649	111	550	1210
600	178	714	270	530	748	111	550	1389

# Type C

## CHAINWHEEL

- Recommended for elevated installations.
- Consists on:
  - Chainwheel: Epoxy coated Cast Iron
  - Stem
  - Stem nut
  - Stem protector
- Available from DN 50 to DN 600
- Options:
  - Locking Device
  - Extension
  - Non-rising Stem

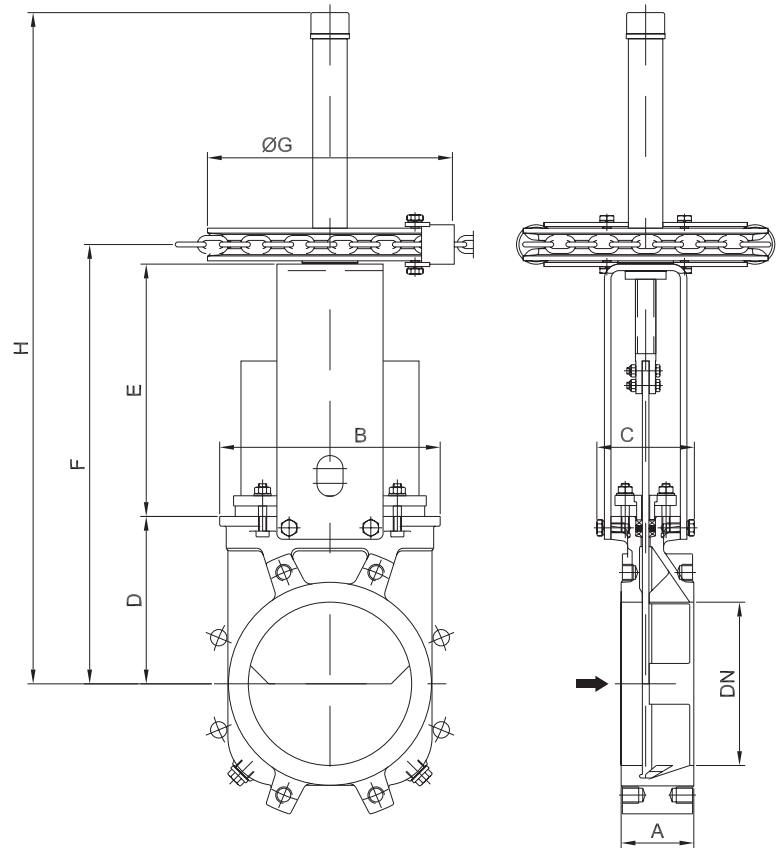

DN	A	B	C	D	E	F	ØG	H
50	46	124	100	105	129	253	225	424
65	46	139	100	115	146	280	225	451
80	64	154	100	124	162	305	225	476
100	64	174	100	140	187	347	225	518
125	70	192	100	150	211	380	225	601
150	76	217	100	170	237	426	225	647
200	89	270	122	205	309	538	300	822
250	114	326	270	240	364	628	300	1012
300	114	380	270	280	414	718	300	1102
350	127	438	270	320	486	838	454	1305
400	140	493	270	350	536	918	454	1385
450	152	546	270	420	588	1040	454	1577
500	152	620	270	450	648	1130	454	1662
600	178	714	270	530	748	1310	454	1962



# Type C

## LEVER

- Recommended for quick opening and closing.
- Consists on:
  - Lever
  - Stem
  - Yoke Sleeve
  - Lever Lock
- Available from DN 50 to DN 300

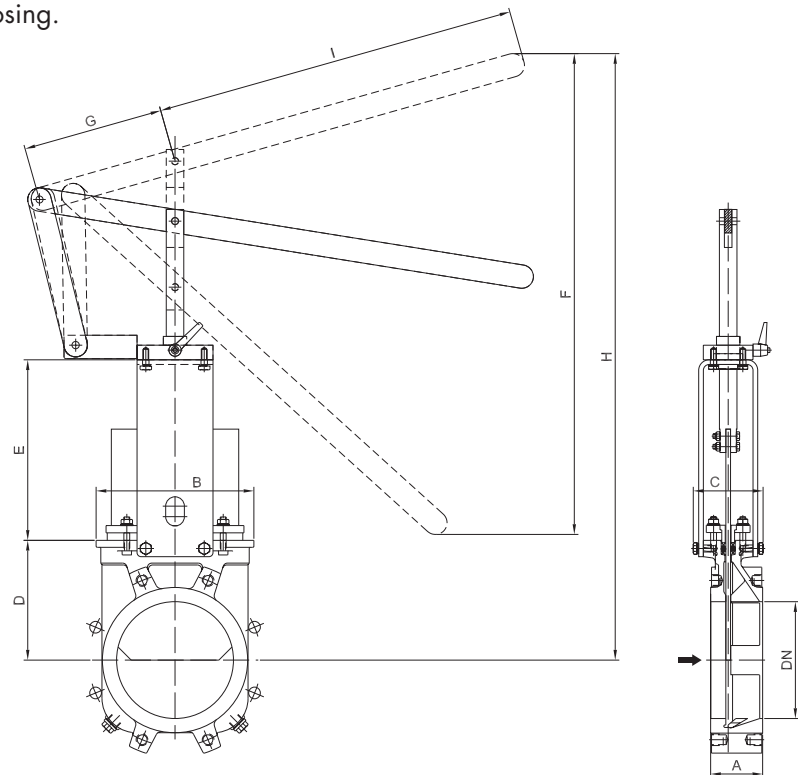

DN	A	B	C	D	E	F	G	H	I
50	46	124	100	105	129	256	150	408	315
65	46	139	100	115	146	259	150	435	315
80	64	154	100	124	162	307	150	509	315
100	64	174	100	140	187	378	150	637	415
125	70	192	100	150	211	439	150	755	415
150	76	217	100	170	237	529	150	890	415
200	89	270	122	205	309	620	235	1038	620
250	114	326	270	240	364	822	235	1297	620
300	114	380	270	280	414	995	235	1558	620

# Type C

## GEAR

- Recommended for valves larger than DN 350 and working pressures greater than 3.5 kg/cm<sup>2</sup>
- Consists on:
  - Stem
  - Yoke
  - Bevel Gear Actuator with Handwheel (Standard Ratio 4:1)
- Available from DN 200 to DN 600
- Options:
  - Locking device
  - Extension
  - Chainwheel
  - Non-rising stem

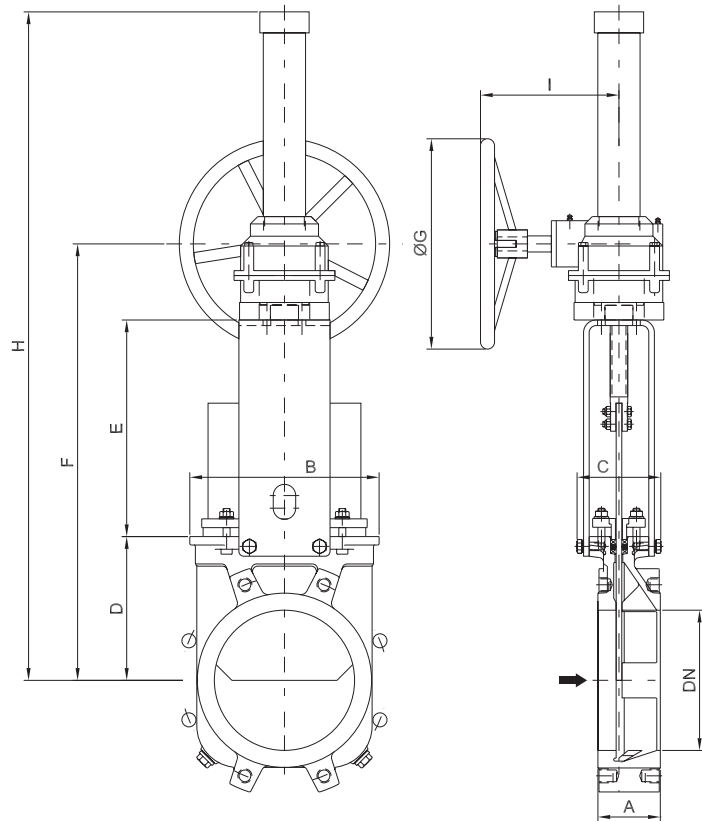

DN	A	B	C	D	E	F	ØG	H	I
200	89	270	122	205	309	623	300	964	198
250	114	326	270	240	364	713	300	1054	198
300	114	380	270	280	414	803	300	1144	198
350	127	438	270	320	500	904	450	1545	218
400	140	493	270	350	550	984	450	1626	218
450	152	546	270	420	598	1102	450	1742	218
500	152	620	270	450	658	1192	450	1833	218
600	178	714	270	530	758	1372	450	2014	218

# Type C

## PNEUMATIC CYLINDER

- The standard pneumatic actuator (double acting on-off cylinder) consists of:
  - Aluminium jacket and covers
  - Stainless Steel (AISI 304) piston rod
  - Nitrile coated steel piston
- Available in DN 50 to DN 600
- Supply Pressure: minimum 3.5 kg/cm<sup>2</sup> - maximum 10 kg/cm<sup>2</sup>
- Reinforced design of support plates (U-type) is standard starting from DN 250.
- Options:
  - Hard anodized jacket and covers
  - Over/Undersized cylinder
  - Stainless Steel jacket and covers
  - Manual override
  - Fail safe system
  - Travel stops
- Instrumentation (on request):
  - Positioners
  - Solenoid valves
  - Flow regulators
  - Air preparation units

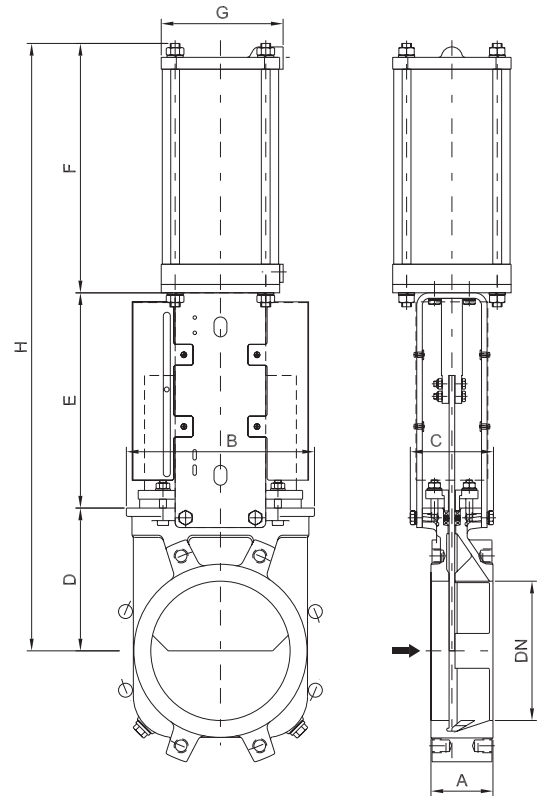

DN	A	B	C	D	E	F	G	H	Weight (kg.)	Standard Cyl.	Connect.
50	46	124	100	105	129	178	115	412	9	C100/62	1/4" G
65	46	139	100	115	146	193	115	454	10	C100/77	1/4" G
80	64	154	100	124	162	211	115	497	11	C100/95	1/4" G
100	64	174	100	140	187	231	115	558	14	C100/115	1/4" G
125	70	192	100	150	211	271	140	632	20	C125/143	1/4" G
150	76	217	100	170	237	296	140	703	25	C125/168	1/4" G
200	89	270	122	205	309	358	175	872	44	C160/220	1/4" G
250	114	326	270	240	364	428	220	1032	67	C200/270	3/8" G
300	114	380	270	280	414	478	220	1172	82	C200/320	3/8" G
350	127	438	270	320	500	549	277	1369	135	C250/375	3/8" G
400	140	493	270	350	550	599	277	1499	165	C250/425	3/8" G
450	152	546	270	420	598	680	382	1698	220	C300/475	1/2" G
500	152	620	270	450	658	730	382	1838	280	C300/525	1/2" G
600	178	714	270	530	758	830	382	2118	330	C300/625	1/2" G

# Type C

## ELECTRIC ACTUATOR

- Consists on:
  - Electric motor
  - Rising stem
  - Motor support yoke flange  
(Acc. to ISO 5210/DIN 3338)
- The standard electric motor is equipped with:
  - Manual emergency operation
  - Limit switches (open/closed)
  - Torque switches
- Available from DN 50 to DN 600
- Wide range of types and marks available to meet customer's needs.
- Option:
  - Non rising stem

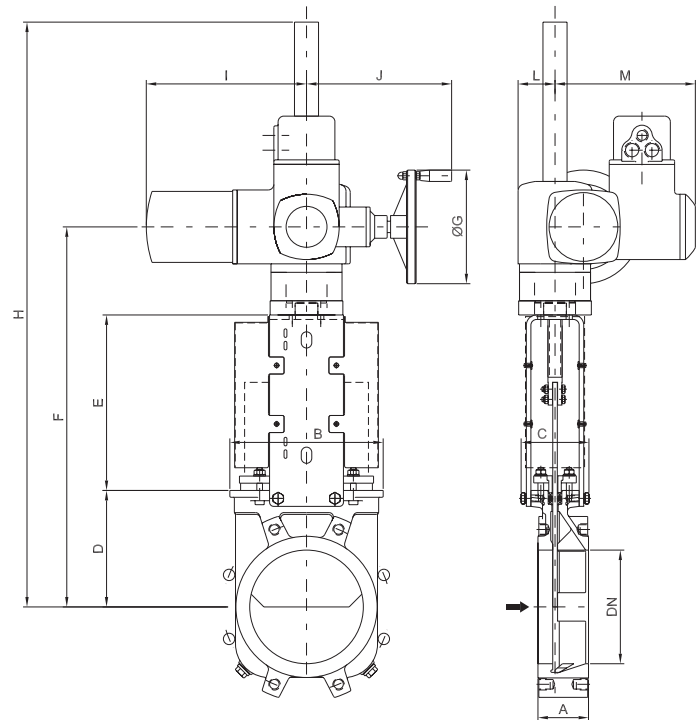

DN	A	B	C	D	E	F	H	ØG	I	J	L	M	stemØ x pitch	Torque(Nm)
50	46	124	100	105	129	337	547	160	265	249	62	237	20 x 4	20
65	46	139	100	115	146	404	574	160	265	249	62	237	20 x 4	25
80	64	154	100	124	162	429	599	160	265	249	62	237	20 x 4	30
100	64	174	100	140	187	470	640	160	265	249	62	237	20 x 4	40
125	70	192	100	150	211	504	674	160	265	249	62	237	20 x 4	50
150	76	217	100	170	237	550	1120	160	265	249	62	237	20 x 4	60
200	89	270	122	205	309	669	1289	200	282	256	65	247	25 x 5	70
250	114	326	270	240	364	759	1339	200	282	256	65	247	25 x 5	80
300	114	380	270	280	414	849	1434	200	282	256	65	247	25 x 5	90
350	127	438	270	320	500	950	1535	200	282	256	85	247	35 x 6	105
400	140	493	270	350	550	1030	1615	200	282	256	85	247	35 x 6	120
450	152	546	270	420	598	1193	1793	315	385	325	90	285	35 x 6	160
500	152	620	270	450	658	1283	1883	315	385	325	90	285	35 x 6	180
600	178	714	270	530	758	1463	2163	315	385	325	90	285	35 x 6	210

# Type C

## FLANGE AND BOLTING DETAILS

### DIN PN10

DN	K	n°	M	T	⌀ ⌀ ⌀
50	125	4	M-16	8	4 - - - -
65	145	4	M-16	8	4 - - - -
80	160	8	M-16	9	4 - 4 - -
100	180	8	M-16	11	4 - 4 - -
125	210	8	M-16	11	4 - 4 - -
150	240	8	M-20	14	4 - 4 - -
200	295	8	M-20	14	4 - 4 - -
250	350	12	M-20	18	6 - 4 - 2
300	400	12	M-20	18	8 - 4 - -
350	460	16	M-20	22	10 - 4 - 2
400	515	16	M-24	21	10 - 4 - 2
450	565	20	M-24	22	14 - 4 - 2
500	620	20	M-24	22	14 - 4 - 2
600	725	20	M-27	24	14 - 4 - 2

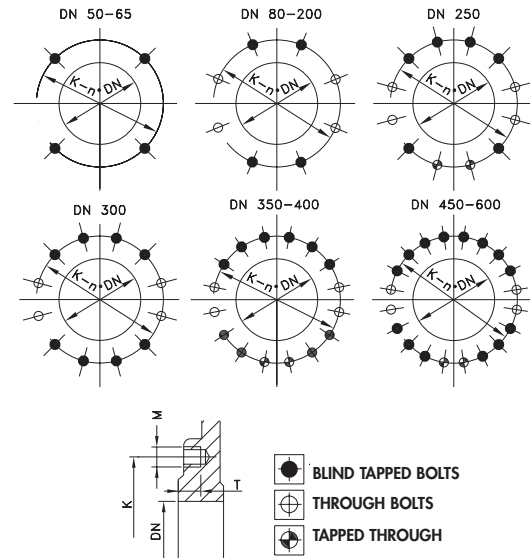

### ANSI B16.5, class 150

DN	K	n°	M	T	⌀ ⌀ ⌀
2"	4 3/4"	4	5/8" UNC	5/16"	4 - - - -
2 1/2"	5 1/2"	4	5/8" UNC	5/16"	4 - - - -
3"	6"	4	5/8" UNC	3/8"	4 - - - -
4"	7 1/2"	8	5/8" UNC	7/16"	4 - 4 - -
5"	8 1/2"	8	3/4" UNC	7/16"	4 - 4 - -
6"	9 1/2"	8	3/4" UNC	9/16"	4 - 4 - -
8"	11 3/4"	8	3/4" UNC	9/16"	4 - 4 - -
10"	14 1/4"	12	7/8" UNC	11/16"	6 - 4 - 2
12"	17"	12	7/8" UNC	11/16"	8 - 4 - -
14"	18 3/4"	12	1" UNC	7/8"	6 - 4 - 2
16"	21 1/4"	16	1" UNC	13/16"	10 - 4 - 2
18"	22 3/4"	16	1 1/8" UNC	7/8"	10 - 4 - 2
20"	25"	20	1 1/8" UNC	7/8"	14 - 4 - 2
24"	29 1/2"	20	1 1/4" UNC	15/16"	14 - 4 - 2

