

NEW

EHEDG certified

Aseptic and hygienic Pinch Valves

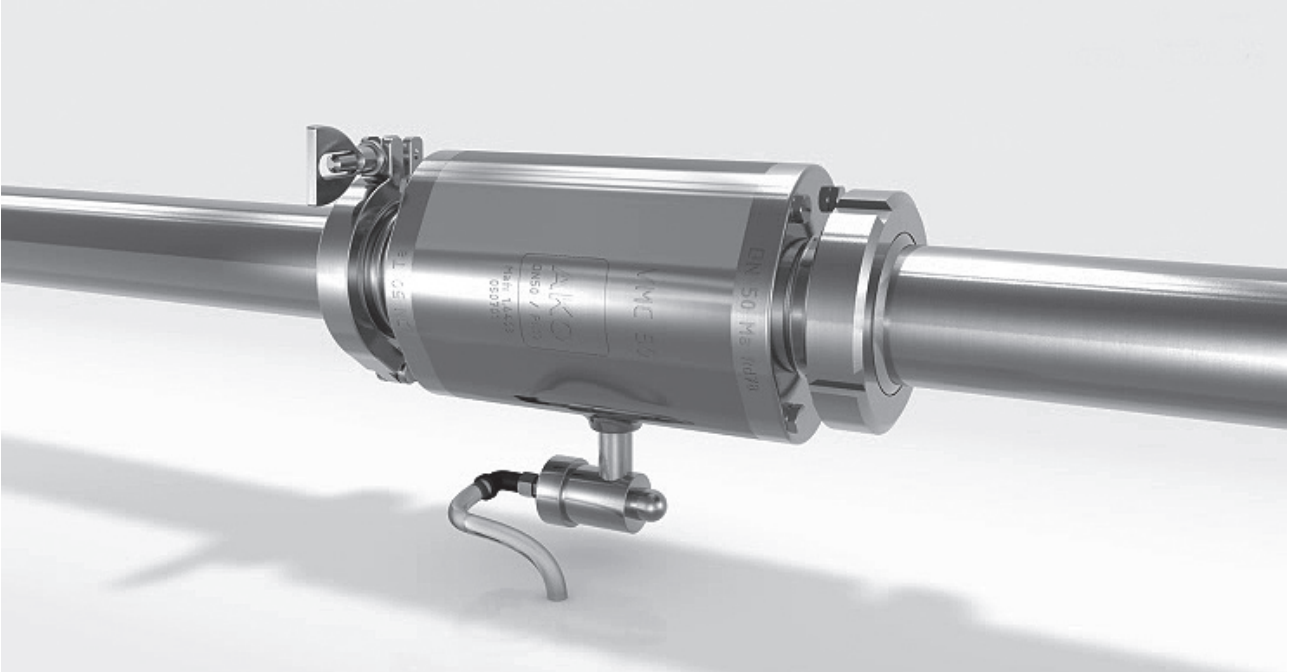

The flexible modular system

Aseptic design for hygienic safe processes

Connections:

- Weld-on ends
- Flange
- Tri-Clamp
- Threaded Spigot (RJT)



Weld-on end



Tri-Clamp



Flange



Threaded spigot

Air operated Pinch Valve type VMCE

The new AKO aseptic Pinch Valves of Series VMCE captivate by their sanitary design.

Excellent cleanability, a flexible modular system, as well as the longevity of the pinch valve sleeve are only three of the advantages of this Pinch Valve type.

Installed in pipes, they take either an absolutely tight open-close shut-off function or can be used with the help of an electro-pneumatic proportional valve for coarse control or dosage of a product stream.

The air operated Pinch Valves Series VMCE are available in nominal sizes DN10-100.

EHEDG certified

The new pinch valves are characterized by an

- easy-to-clean (**CIP**),
- sterilizable (**SIP**-capable), and
- bacteria-tight design

in accordance with **EHEDG certification type EL Class I** and **Type EL ASEPTIC Class I**.

Furthermore, the VMCE pinch valves are piggable (**RIP**).

Operating / medium pressure max.: ~ 6 bar

Control / closing pressure max.: 8 bar

Differential pressure: 2-2.5 bar

varies depending on diameter

The air operated Pinch Valves of VMCE series fulfill all requirements of the Pressure Equipment Directive 97/23/EC.

Technical details subject to change without notice.

AKO UK Ltd.

12 Rutherford Way, Drayton Fields Industrial Estate, Daventry, NN11 8XW, Great Britain

Tel: 0 13 27 31 27 47 • Fax: 0 13 27 31 25 65 • E-mail: sales@ako-valves.com • Web: www.pinch-valves.com

Air operated Pinch Valve with Weld-on ends (R)

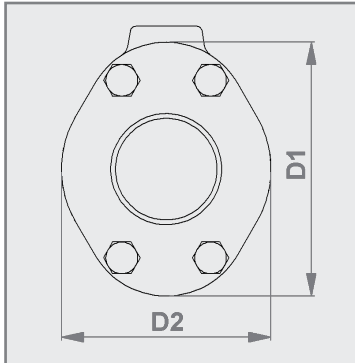

DN10 - DN50

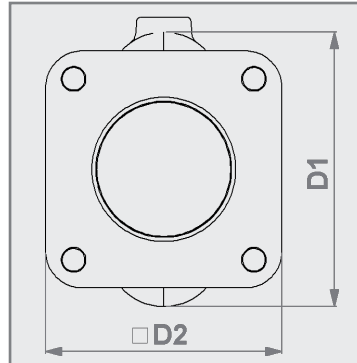

DN65 - DN100

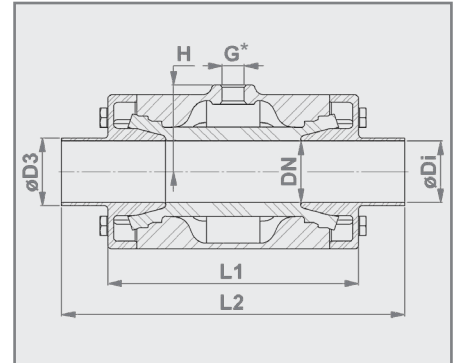

* DIN EN ISO 228 "G"

Connection type:

Weld-on ends according to
DIN 11850 row 2

Body:

Stainless steel 1.4408

Weld-on ends:

Stainless steel 1.4404

Sleeve:

EPDM

Valve face to face length:

DN 10: Acc. to DIN EN 558 row 27
 DN 15-50: Acc. to DIN EN 12982 row 1
 DN 65-100: Acc. to DIN EN 558 row 7

Valve finish:

Stainless steel: Electropolished matt

Wetted parts = Ra 0.5.

Satin polished (brushed) Ra 0.3 on request.



DN (mm)	ø Di (mm)	D1 (mm)	D2 (mm)	ø D3 (mm)	L1 (mm)	L2 (mm)	G (inch)	H (mm)	¹ Vol. (l) (approx.)	weight (kg)
10	10	46	35	13x1,5	68	115	G 1/8"	23	0,03	0,5
15	16	56	47	19x1,5	85	140	G 1/8"	28	0,05	0,8
20	20	62	49	23x1,5	93	152	G 1/8"	32	0,07	1,0
25	26	72	57	29x1,5	110	165	G 1/8"	37	0,09	1,4
32	32	80	66	35x1,5	130	178	G 1/4"	45	0,13	1,9
40	38	90	77	41x1,5	150	190	G 1/4"	50	0,22	2,5
50	50	110	88	53x1,5	175	216	G 1/4"	60	0,36	3,8
65	66	139	115	70x2	173	216	G 1/4"	74	0,44	4,2
80	81	173	133	85x2	213	254	G 1/4"	90	0,88	6,0
100	100	203	156	104x2	264	305	G 1/4"	107	1,80	11,3

¹ Volume = Control volume with closed sleeve

Technical details subject to change without notice.

AKO UK Ltd.

12 Rutherford Way, Drayton Fields Industrial Estate, Daventry, NN11 8XW, Great Britain

Tel: 0 13 27 31 27 47 • Fax: 0 13 27 31 25 65 • E-mail: sales@ako-valves.com • Web: www.pinch-valves.com

Air operated Pinch Valve with Weld-on ends (RA)

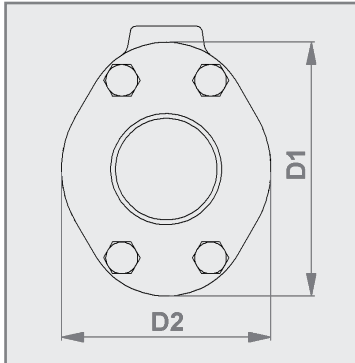

DN10 - DN50

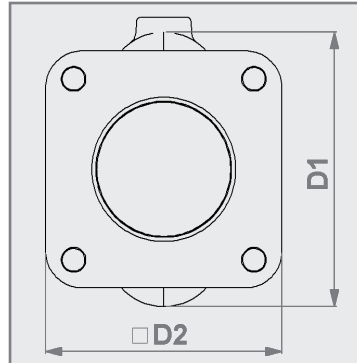

DN65 - DN100

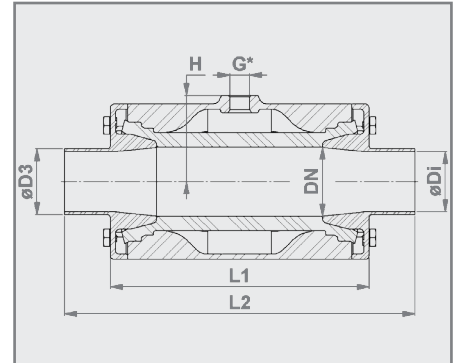

* DIN EN ISO 228 "G"

Connection type:

Weld-on ends according to
ASTM A554

Body:

Stainless steel 1.4408

Weld-on ends:

Stainless steel 1.4404

Sleeve:

EPDM

Valve finish:

Stainless steel: Electropolished matt

Wetted parts = Ra 0.5.

Satin polished (brushed) Ra 0.3 on request.



DN (mm)	ø Di (mm)	D1 (mm)	D2 (mm)	ø D3 (mm)	L1 (mm)	L2 (mm)	L2 (inch)	G (inch)	H (mm)	¹ Vol. (l) (approx.)	weight (kg)
10	7,75	46	35	9,53	68	101,6	4	G 1/8"	23	0,03	0,5
15	9,40	56	47	12,70	85	127,0	5	G 1/8"	28	0,05	0,8
20	15,75	62	49	19,05	93	152,4	6	G 1/8"	32	0,07	1,0
25	22,10	72	57	25,40	110	152,4	6	G 1/8"	37	0,09	1,5
40	34,80	90	77	38,10	150	203,2	8	G 1/4"	50	0,22	2,6
50	47,50	110	88	50,80	175	228,6	9	G 1/4"	60	0,36	3,9
65	60,20	139	115	63,50	173	228,6	9	G 1/4"	74	0,44	4,3
80	72,90	173	133	76,20	213	279,4	11	G 1/4"	90	0,88	6,2
100	97,38	203	156	101,60	264	330,2	13	G 1/4"	107	1,80	11,6

¹ Volume = Control volume with closed sleeve

Technical details subject to change without notice.

AKO UK Ltd.

12 Rutherford Way, Drayton Fields Industrial Estate, Daventry, NN11 8XW, Great Britain

Tel: 0 13 27 31 27 47 • Fax: 0 13 27 31 25 65 • E-mail: sales@ako-valves.com • Web: www.pinch-valves.com

Air operated Pinch Valve with Flange (RF)

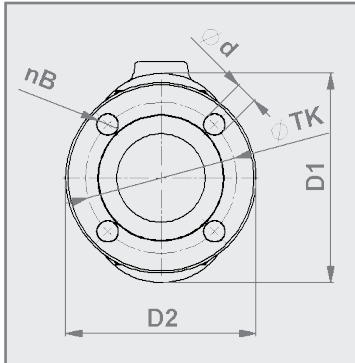

DN10 - DN50

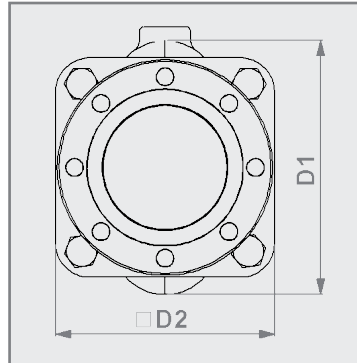

DN65 - DN100

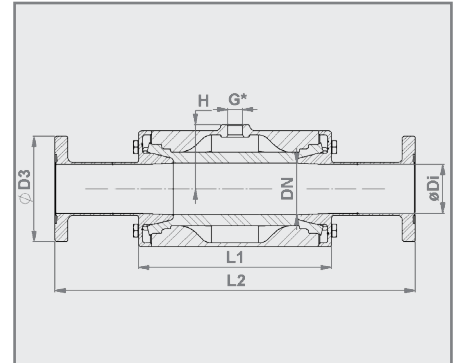

* DIN EN ISO 228 "G"

Connection type:

Flange connection according to

DIN 11853-2 (BF)

DIN 11864-2 form A (BF) (DN40-50)

Body:

Stainless steel 1.4408

Flange:

Stainless steel 1.4404

Sleeve:

EPDM

Valve finish:

Stainless steel: Electropolished matt

Wetted parts = Ra 0.5.

Satin polished (brushed) Ra 0.3 on



DN (mm)	DI (mm)	D1 (mm)	D2 (mm)	ø D3 (mm)	nB	ø d (mm)	ø TK (mm)	L1 (mm)	L2 (mm)	G (inch)	H (mm)	Vol. (l) (approx.)	weight (kg)
10	10	46	35	54	4	9	37	68	163	G 1/8"	23	0,03	0,9
15	16	56	47	59	4	9	42	85	188	G 1/8"	28	0,05	1,2
20	20	62	49	64	4	9	47	93	200	G 1/8"	32	0,07	1,5
25	26	72	57	70	4	9	53	110	213	G 1/8"	37	0,09	2,0
32	32	80	66	76	4	9	59	130	226	G 1/4"	45	0,13	2,5
40	38	90	77	82	4	9	65	150	280	G 1/4"	50	0,22	3,2
50	50	110	88	94	4	9	77	175	306	G 1/4"	60	0,36	4,7
65	66	139	115	113	8	9	95	173	264	G 1/4"	74	0,44	5,5
80	81	173	133	133	8	11	112	213	306	G 1/4"	90	0,88	7,9
100	100	203	156	159	8	11	137	264	357	G 1/4"	107	1,80	14,2

* Number of holes

* Volume = Control volume with closed sleeve

Technical details subject to change without notice.

AKO UK Ltd.

12 Rutherford Way, Drayton Fields Industrial Estate, Daventry, NN11 8XW, Great Britain

Tel: 0 13 27 31 27 47 • Fax: 0 13 27 31 25 65 • E-mail: sales@ako-valves.com • Web: www.pinch-valves.com

Air operated Pinch Valve

with Tri-Clamp connection (RT)

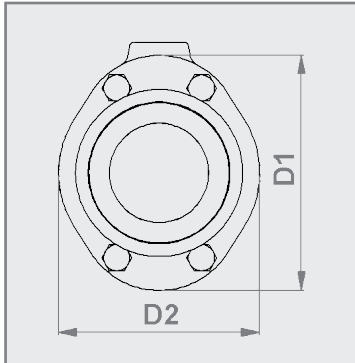

DN10 - DN50

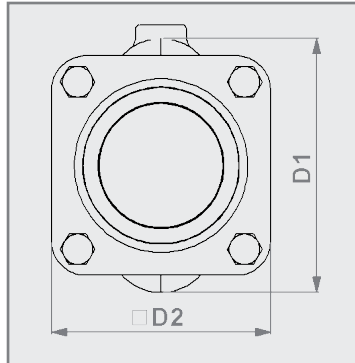

DN65 - DN100

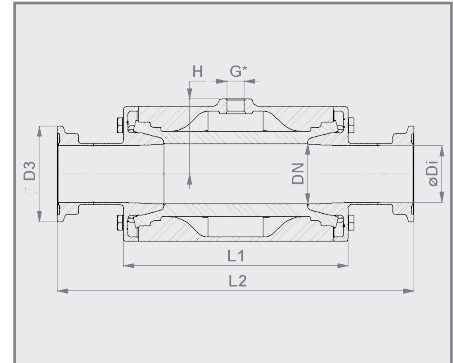

* DIN EN ISO 228 "G"

Connection type:

Tri-Clamp according
DIN 11853-3 (BKS)

Body:

Stainless steel 1.4408

Tri-Clamp Connection:

Stainless steel 1.4404

Sleeve:

EPDM

Valve finish:

Stainless steel: Electropolished matt

Wetted parts = Ra 0.5.

Satin polished (brushed) Ra 0.3 on



DN (mm)	ø D1 (mm)	D1 (mm)	D2 (mm)	ø D3 (mm)	L1 (mm)	L2 (mm)	G (inch)	H (mm)	¹ Vol. (l) (approx.)	weight (kg)
10	10	46	35	34	68	159	G 1/8"	23	0,03	0,6
15	16	56	47	34	85	184	G 1/8"	28	0,05	0,9
20	20	62	49	50,5	93	196	G 1/8"	32	0,07	1,3
25	26	72	57	50,5	110	209	G 1/8"	37	0,09	1,7
32	32	80	66	50,5	130	226	G 1/4"	45	0,13	2,4
40	38	90	77	64	150	238	G 1/4"	50	0,22	3,0
50	50	110	88	77,5	175	265	G 1/4"	60	0,36	4,4
65	66	139	115	91	173	269	G 1/4"	74	0,44	5,0
80	81	173	133	106	213	311	G 1/4"	90	0,88	7,0
100	100	203	156	130	264	365	G 1/4"	107	1,80	13,0

¹ Volume = Control volume with closed sleeve

Technical details subject to change without notice.

AKO UK Ltd.

12 Rutherford Way, Drayton Fields Industrial Estate, Daventry, NN11 8XW, Great Britain

Tel: 0 13 27 31 27 47 • Fax: 0 13 27 31 25 65 • E-mail: sales@ako-valves.com • Web: www.pinch-valves.com

Air operated Pinch Valve with Threaded spigot (RM)

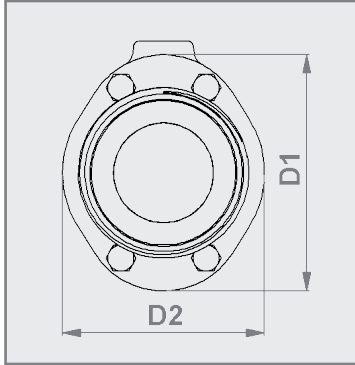

DN10 - DN50

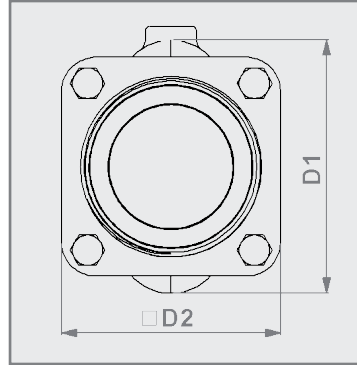

DN65 - DN100

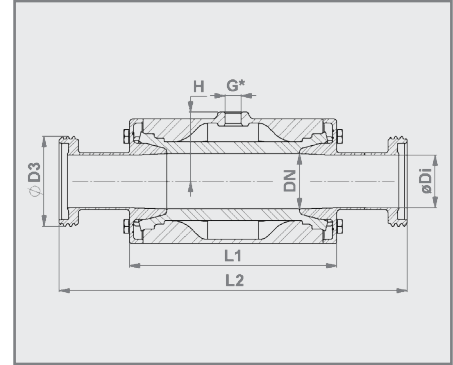

* DIN EN ISO 228 "G"

Connection type:

Threaded spigot according
DIN 11853-1 (GS)

Body:

Stainless steel 1.4408

Threaded spigot:

Stainless steel 1.4404

Sleeve:

EPDM

Valve finish:

Stainless steel: Electropolished matt

Wetted parts = Ra 0.5.

Satin polished (brushed) Ra 0.3 or



DN (mm)	ø Di (mm)	D1 (mm)	D2 (mm)	D3	G (inch)	H (mm)	L1 (mm)	L2 (mm)	¹ Vol. (l) (approx.)	weight (kg)
10	10	46	35	Rd28x1/8"	G 1/8"	23	68	153	0,03	0,6
15	16	56	47	Rd34x1/8"	G 1/8"	28	85	178	0,05	1,0
20	20	62	49	Rd44x1/6"	G 1/8"	32	93	194	0,07	1,2
25	26	72	57	Rd52x1/6"	G 1/8"	37	110	217	0,09	1,8
32	32	80	66	Rd58x1/6"	G 1/4"	45	130	238	0,13	2,3
40	38	90	77	Rd65x1/6"	G 1/4"	50	150	252	0,22	3,0
50	50	110	88	Rd78x1/6"	G 1/4"	60	175	278	0,36	4,4
65	66	139	115	Rd95x1/6"	G 1/4"	74	173	288	0,44	5,2
80	81	173	133	Rd110x1/4"	G 1/4"	90	213	338	0,88	7,4
100	100	203	156	Rd130x1/4"	G 1/4"	107	264	405	1,80	13,0

¹ Volume = Control volume with closed sleeve

Technical details subject to change without notice.

AKO UK Ltd.

12 Rutherford Way, Drayton Fields Industrial Estate, Daventry, NN11 8XW, Great Britain

Tel: 0 13 27 31 27 47 • Fax: 0 13 27 31 25 65 • E-mail: sales@ako-valves.com • Web: www.pinch-valves.com